

Contents

ENGLISH	2
Vehicle Details	2
Adapter Kit Details	2
Compatible Compressors	3
Compressor Kit Configurations	3
Installation Precautions	4
Standard Fastener Torque Values	4
Parts View and List	5
Pre Installation	6
Installation	6
Compressor Installation	6
Drive Belt Installation	7
Finish	7
Notes	8

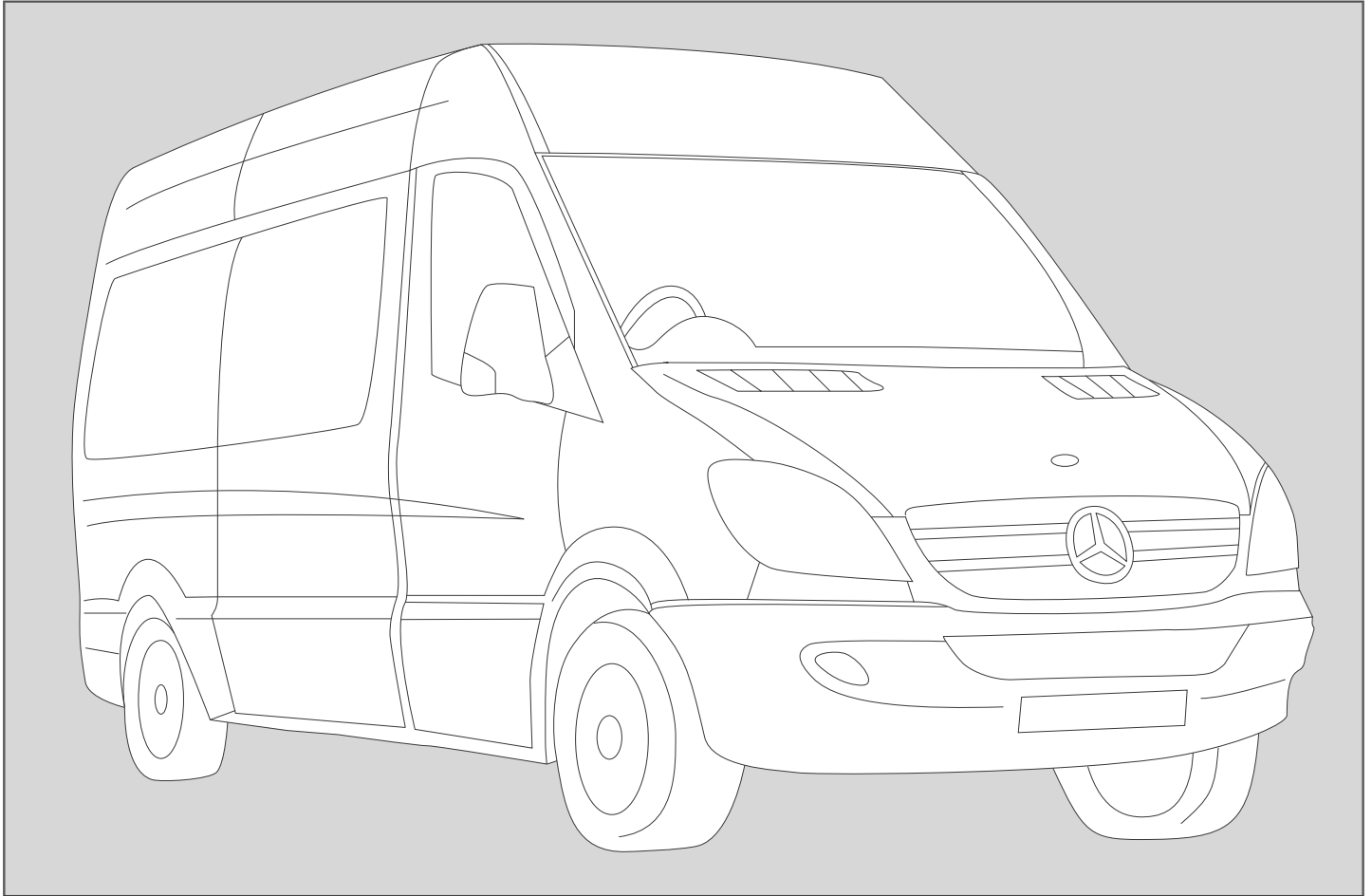

VEHICLE DETAILS

Manufacturer	Mercedes Benz
Make	Sprinter
Model	219 CDi / 319 CDi / 419 CDi / 519 CDi
Engine CC	OM642 Euro 4/ 5 / EEV
Engine Details	OM642 V6 CDi
Year	08.2009>
Chassis Nos.	N/A
LHD	YES
RHD	YES
PAS	YES
A/C	YES / NO
Voltage	12v

ADAPTER KIT DETAILS

Kit Part No.	0500.3682
Description	Standard Kit
Compressor RPM	4695 @ Max Engine
	Power Output
Fitting Time	40 Minutes
Suction Fitting	90°
Discharge Fitting	90°
Belt Type	6PK 1400
Belt Part No.	0820.1861
Note	Vehicles With Factory Fitted N63 Option

COMPATIBLE COMPRESSORS

SELTEC	TM-13 HS	TM15-HS	TM16-HS
Comp No	0381.0202	0381.0002	0381.0312
Seltec No.	435.54120	435.55120	435.56134
Mounting	Ear	Ear	Ear
Rotor	8PV	8PV	8PV
Armature	3E	3E	3E
Diameter	123	123	123
Voltage	12	12	12
Orientation	V	V	V
Fitting	3/4 x 7/8	3/4 x 7/8	3/4 x 7/8
Manifold	Bolt	Bolt	Bolt

QUE	QP13-HD	QP15-HD	QP16-HD
Comp No	0391.0202	0391.0002	0391.0312
Que No.	QP13.1302	QP15.1171	QP16.1195
Mounting	Ear	Ear	Ear
Rotor	8PV	8PV	8PV
Armature	3E	3E	3E
Diameter	123	123	123
Voltage	12	12	12
Orientation	V	V	V
Fitting	3/4 x 7/8	3/4 x 7/8	3/4 x 7/8
Manifold	Bolt	Bolt	Bolt

SANDEN	SD5H09	SD5H14	SD5H15
Comp No	-	-	-
Sanden No	-	-	-
Mounting	-	-	-
Rotor	-	-	-
Armature	-	-	-
Diameter	-	-	-
Voltage	-	-	-
Orientation	-	-	-
Fitting	-	-	-

Notes

COMPRESSOR KIT CONFIGURATIONS

PART NUMBER	COMPRESSOR KIT PART NOS						DESCRIPTION	QTY.
	0513.6802	0515.6802	0516.6802	0593.6802	0595.6802	0596.6802		
0381.0202	●						TM13 Ear Mount 8PV 3E 123 12V V 3/4 x 7/8 Bolt	1
0381.0002		●					TM15 Ear Mount 8PV 3E 123 12V V 3/4 x 7/8 Bolt	1
0381.0312			●				TM16 Ear Mount 8PV 3E 123 12V V 3/4 x 7/8 Bolt	1
0391.0202				●			QP13 Ear Mount 8PV 3E 123 12V V 3/4 x 7/8 Bolt	1
0391.0002					●		QP15 Ear Mount 8PV 3E 123 12V V 3/4 x 7/8 Bolt	1
0391.0312						●	QP16 Ear Mount 8PV 3E 123 12V V 3/4 x 7/8 Bolt	1

● = Additional parts to standard kits.

FOREWORD

1. The purpose of this manual is to facilitate the installation of a direct drive compressor. The information given is merely instructive, should any complications arise contact the Technical department. The manufacturer's warranty does not cover any problems caused by defective installation or alterations made unless authorised. The manufacturer shall not be responsible for any injury, damage or loss caused directly or indirectly as a result of using this manual or the information contained within it.

1 SAFETY MEASURES:

Before fitting the Compressor adapter drive kit, ensure the following for damage:

- a Inner and outer trim and body work
- b Engine idle pace
- c Check all the vehicle functions

Check list:

- a Ensure that the right kit has been selected
- b Before installing, check that all the correct pieces are present; also ensure that there are no missing or broken pieces
- c When fitting, make sure the vehicle is properly protected against damage.

Installation apparatus

- a Calibrated torque wrench
- b Hand service tools
- c Protective covers and shields

2 PRECAUTIONS

- a Detach the battery negative lead.
- b Torque all bolts where stated using a calibrated torque wrench.
- c Take extreme care with moving parts.
- d Remove the vehicles ignition key and keep it with you.
- e Wear safeguards to make sure that liquid refrigerant never touches your skin





Caution: Measures must be followed accurately to steer clear of the possibility of damage to individuals

Warning: This calls awareness to actions which must be pursued to avoid damage to the components.

NB: This calls awareness to make the job easier or gives useful information.

STANDARD FASTENER TORQUE VALUES

1. In the absence of specific torque values detailed in this fitting instruction manual, the following chart can be used as a guide to the maximum safe torque for specific size and grade of fastener.

STRENGTH								
	Max Torque		Max Torque		Max Torque		Max Torque	
Dia / Pitch	lb.ft	Nm	lb.ft	Nm	lb.ft	Nm	lb.ft	Nm
M5 x 0.80	2	3	4.5	6	6.5	9	7.5	10
M6 x 1.00	4	5.5	7.5	10	11	15	13	18
M8 x 1.25	10	13	18	25	26	35	33	45
M10 x 1.25	20	27	39	53	57	78	66	90
M10 x 1.50	18	25	37	50	55	73	63	86
M12 x 1.75	33	45	63	85	97	130	111	150
M14 x 2.00	55	75	103	140	151	205	177	240
M16 x 2.00	85	115	159	215	232	315	273	370

PARTS VIEW

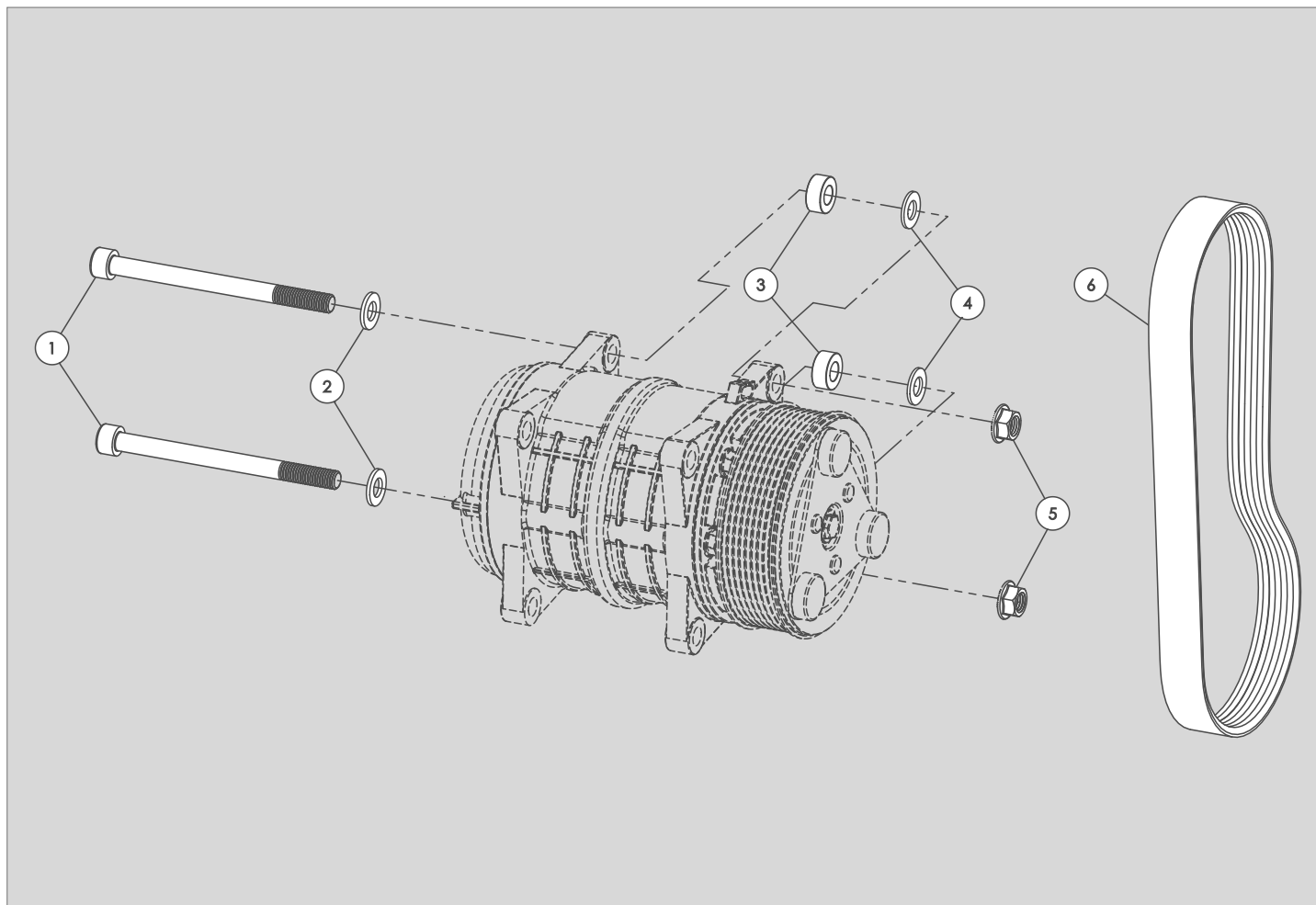

ITEM	PART NO.	DESCRIPTION	QTY.	COMMENTS
1	2705.0301	Hexagon socket head cap screw M10 x 130:1.50 - 12.9	2	-
2	2809.0011	Washer M10 Flat DIN 125 - A 10.5	2	-
3	2803.9013	Spacer - 20.00 OD x 10.40 ID x 8.4	2	-
4	2803.9023	20.00 OD x 10.50 ID x 1.60	2	-
5	2735.0071	Durlok Hexagon Flange Nut - M 10 : 1.50	2	-
6	0820.1861	Belt - Poly Groove 6PK 1400	1	-

PRE-INSTALLATION

Note: Before proceeding please read the installation precautions. The letters on drawings relate to text, numbers circled relate to the parts list in this manual.

INSTALLATION

1. Remove and discard the original stretch belt (A) from the fan assembly – Fig 1
2. Remove and retain bolt (B) securing the fan support tube – Fig 1
3. Disconnect the wiring plug (C) from the fan assembly – Fig 1

Note: It is not necessary to remove the viscous fan to install this mount kit.

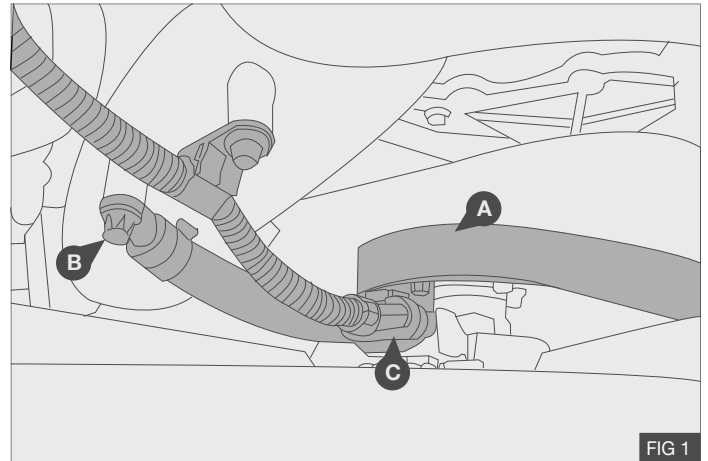

FIG 1

COMPRESSOR INSTALLATION

Note: Washers (2) are very similar in appearance to the spacers (4), the washers are pressed and 2mm thick and the spacers are turned and 1.6mm thick. Identify and separate the spacers (4) from the washers (2) before proceeding with the compressor installation.

1. Install the compressor to the mount bracket (D) using M10 x 130 bolts (1) fitted with 2mm thick washers (2). Place the 8.4mm spacers (3) between the rear compressor ears and the bracket, Insert the 1.6mm spacers (4) between the front compressor ears and the mount bracket (See note below) – Fig 2 .
2. Fit nut (5) to the compressor securing bolts (1) - Fig 2
3. Torque the 2x bolts (1) to 63 Nm / 46 lb ft using a calibrated torque wrench – Fig 2.

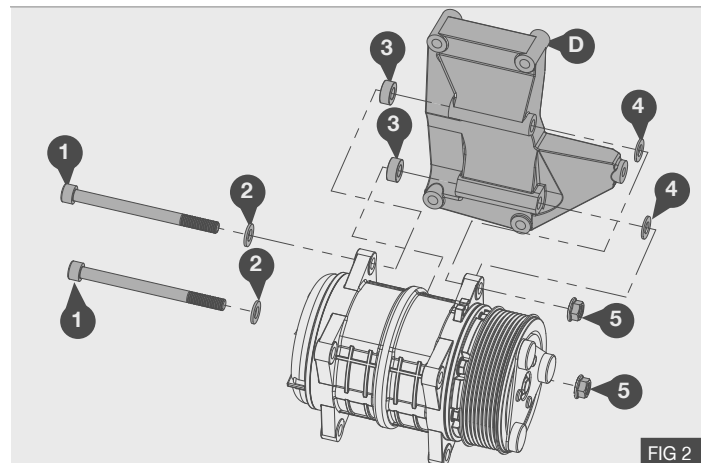

FIG 2

DRIVE BELT INSTALLATION

1. Feed the supplied belt over the viscous fan and install the drive belt as shown opposite - Fig.3

- A** Crankshaft Pulley
- B** Tensioner Pulley
- C** Compressor
- D** Idle Pulley
- E** Fan Pulley

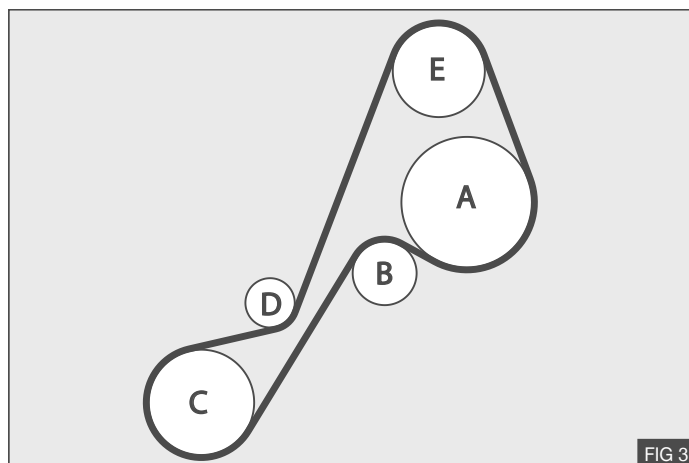

FIG 3

NB: Make sure that the drive belt is fitted into the correct groove of the compressor clutch as shown – Fig 4. Seltec PV8 has the same gauge line as the Sanden PV7, the belt is fitted to the second groove. Sanden PV8 has a unique gauge line, the belt is fitted to the rear of the clutch.

FINISH

1. Refit bolt (B) securing the fan support tube – Fig 1
2. Reconnect the wiring plug (C) from the fan assembly – Fig 1
3. Run the engine with the compressor clutch engaged for five minutes, Check all components.
4. Install the supplied belt label in the engine bay.

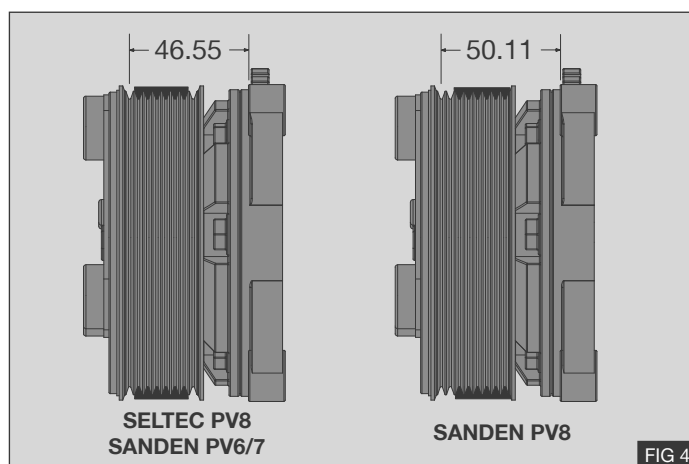

FIG 4

Notes